

MOD	LOC	DIST	P	F	ZONE	LTR	DESCRIPTION	DATE	APPD
2	BD	36				N	REDRAWN W/O CHANGE PER EC 0020-1084-94	10/26/94	TC

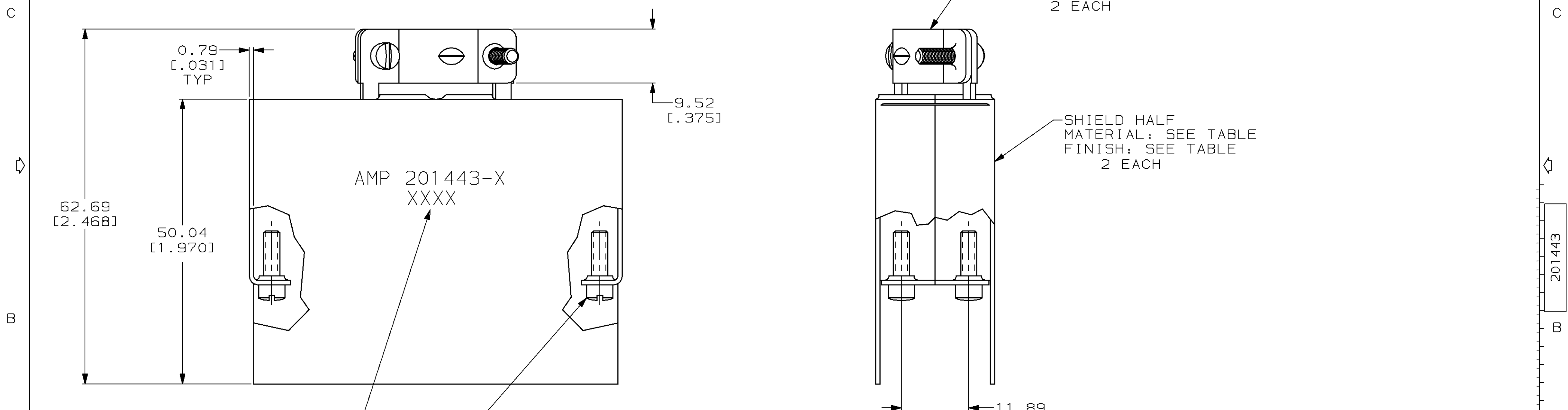
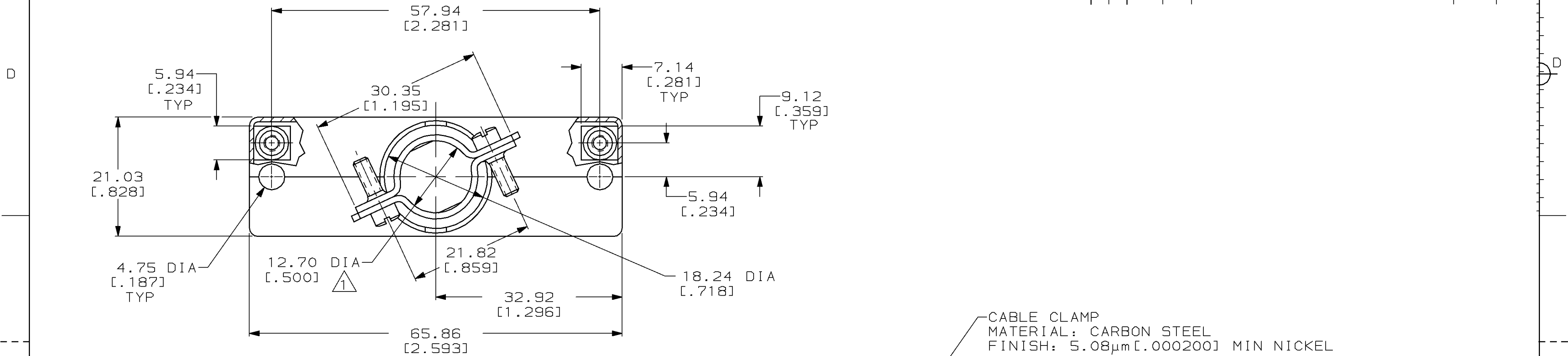

AMP, PART NUMBER AND DATE CODE, INK STAMPED IN THIS AREA

#4-40 UNC-2A SCREW MATERIAL: CARBON STEEL FINISH: ZINC PLATED 6 EACH

△ CLAMP AREA ACCEPTS 50 WIRES OF 1.65 [.065] MAX OUTSIDE DIAMETER.

5.08µm [.000200] MIN NICKEL	CARBON STEEL	201443-2
CLEAR ANODIZED	ALUMINUM ALLOY	201443-1
FINISH	MATERIAL	

SHEILD HALF		PART NO	
DO NOT SCALE PRINT. UNLESS SPECIFIED DIMENSIONS IN mm [INCHES] TOLERANCES ON : 2 PLC DEC ±0.38 [.015] 3 PLC DEC ± - ANGLES ± -	DR 10/26/94 K.FOLTZ	AMP Incorporated Harrisburg, PA 17105-3608	
MATERIAL	CHK 11/07/94 R.STONE		
SEE CALLOUTS	APPD 01/26/95 T.COULSON	NAME	
FINISH	APPD 01/26/95 T.COULSON	SHIELD KIT, UNASSEMBLED, LONG 50 POSITION, M SERIES	
SEE CALLOUTS	PRODUCT SPEC	SIZE	CAGE CODE
	APPLICATION SPEC	SCALE	DRAWING NO
	WEIGHT	2:1	00779
			201443
			SHEET 1 OF 1

THIS DRAWING IS A CONTROLLED DOCUMENT FOR AMP INCORPORATED. IT IS SUBJECT TO CHANGE AND THE CONTROLLING ENGINEERING ORGANIZATION SHOULD BE CONTACTED FOR THE LATEST REVISION.